



Custom Service & Design, Inc.

P.O. Box 214923
Auburn Hills, MI 48321

Phone: 248.340.9005
Fax: 248.340.9002

BULLETIN: 07A4L01-1

OEM BAG VESSEL DESIGN

CSD's NEW OEM BAG VESSEL DESIGN IS SETTING NEW STANDARDS IN THE FILTRATION INDUSTRY. UTILIZING STANDARD BAG SIZES (P1S & P2S) AND MAINTAINING 150 PSI RATING. THIS UNIQUE STATE-OF-THE-ART VESSEL IS THE MOST COMPETITIVELY PRICED VESSEL ON THE MARKET.

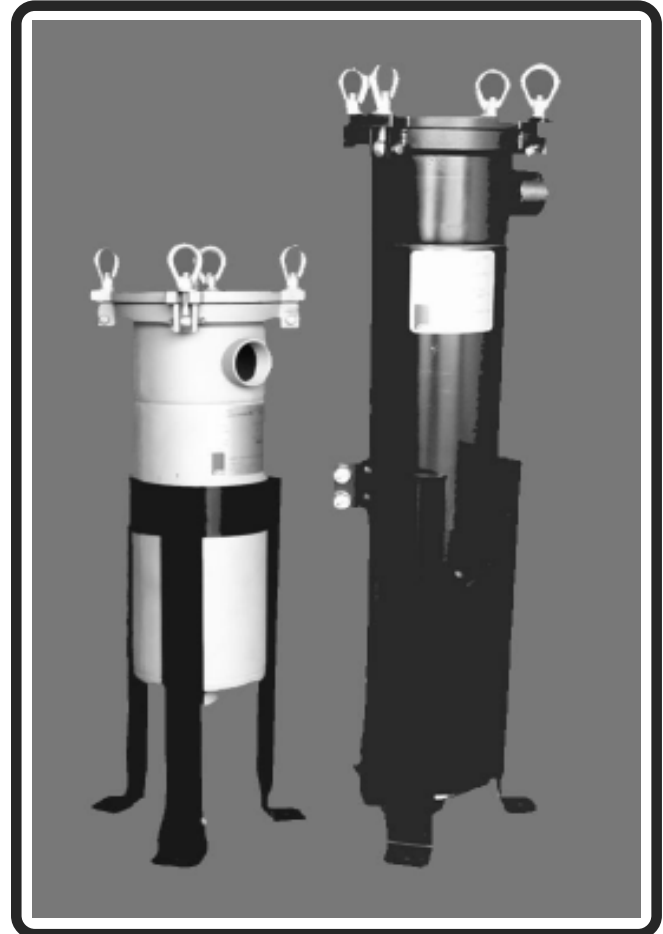

STANDARD FEATURES:

- CARBON STEEL
- 304 STAINLESS STEEL
- STAINLESS STEEL RESTRAINER BASKETS
- 150 PSI @ 300F
- 4 LUG LID HOLDDOWN
- GAUGE, VENT, DRAIN PORTS
- 2" NPT CONNECTIONS
- SIDE INLET / BOTTOM OUTLET
- BUNA / EPDM SEALS
- TRIPOD LEGS (ADJUSTABLE)

OPTIONS:

- ADDITIONAL INLET / OUTLET SIZES
- INLET / OUTLET LOCATION
- FLANGED, VICTOLIC, SANITARY CONNECTIONS
- MANUAL / AUTOMATIC DUPLEXING
- RESTRAINER BASKET PERFORATION / MESH SIZES
- O RING / SEAL MATERIAL
- BAG HOLD DOWN ASSEMBLY
- SPECIALTY VESSELS

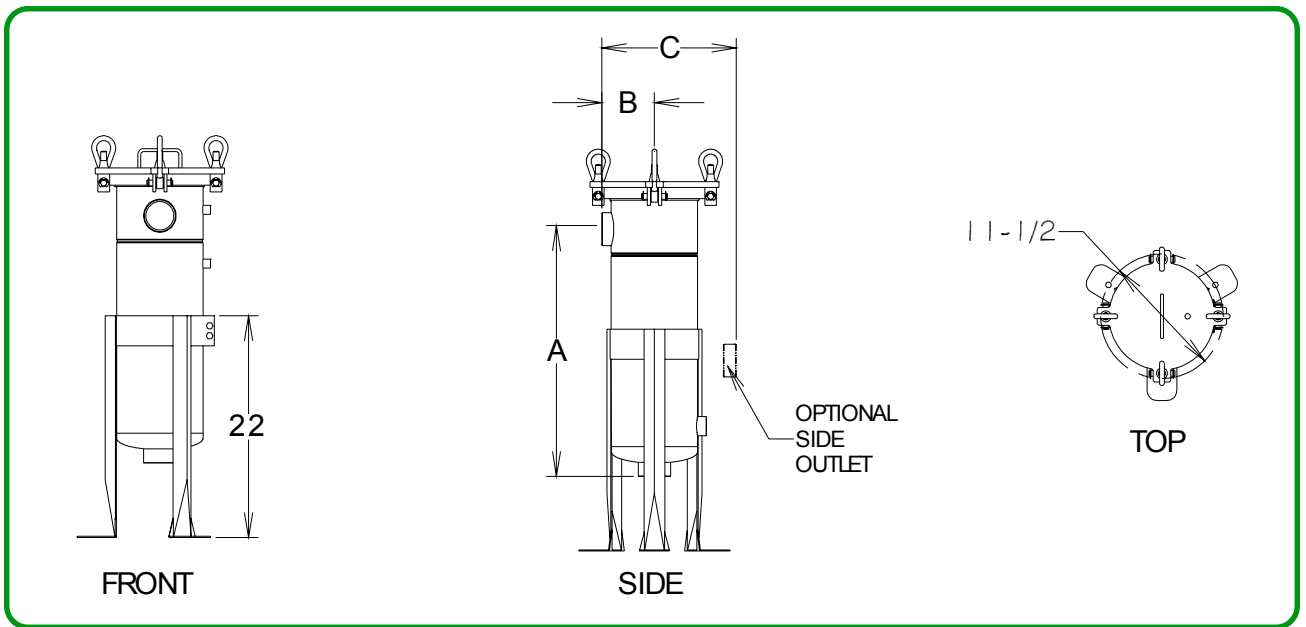

VESSEL	SIZE	A	B	C
15	2" NPT	20-3/4	4-7/16	8-7/8
30	2" NPT	33-3/4	4-7/16	8-7/16

BUILDING A CSD PART NUMBER

007A1304L020N1BC

TYPE	VESSEL	# OF ELEMENTS	BASKET LENGTH	VESSEL DESIGN	CONNECTION SIZE	STYLE	INLET / OUTLET LOCATION	SEALS	CONSTRUCTION
0	07	01	30	4L	020	N	1	B	C
REGULAR	07	1	30"	4 LUG	2"	NPT	SIDE IN / BOTTOM OUT	BUNA	CARBON STEEL

Distributed By:



Custom Service & Design, Inc.

PHONE: 248.340.9005

FAX: 248.340.9002