



**Custom Service & Design, Inc.**

P.O. Box 214923  
AUBURN HILLS, MI 48321

PHONE: 248.340.9005  
FAX: 248.340.9002

WWW.CUSTOMSERVICEANDESIGN.COM

**MULTI BAG LINE**  
**BULLETIN: MB-10-1**

## MULTI BAG VESSEL LINE

**CSD's** Multi-Bag Vessel design is setting new standards in the filtration industry.

Utilizing Industry Standard Bag & Cartridge sizes maintaining 150 PSI rating.

**CSD's** state-of-the-art vessel is the most competitively priced vessel on the market.

**CSD** VESSELS ARE  
AMERICAN MADE & INDUSTRIAL GRADE  
ENSURING QUALITY & SAFETY



### **STANDARD FEATURES:**

- ⇒ CARBON STEEL
- ⇒ 304 STAINLESS STEEL
- ⇒ 316 STAINLESS STEEL
- ⇒ STAINLESS STEEL RESTRAINER BASKETS
- ⇒ 150 P.S.I.
- ⇒ VENT PORTS
- ⇒ GAUGE PORTS
- ⇒ BOTTOM DRAIN PORT
- ⇒ BUNA / EPDM O RING / SEALS
- ⇒ BUILT TO ASME STANDARDS

### **OPTIONS:**

- ⇒ O RING / SEAL MATERIAL
- ⇒ INLET / OUTLET LOCATIONS
- ⇒ DUPLEX
- ⇒ VARIOUS RESTRAINER BASKETS



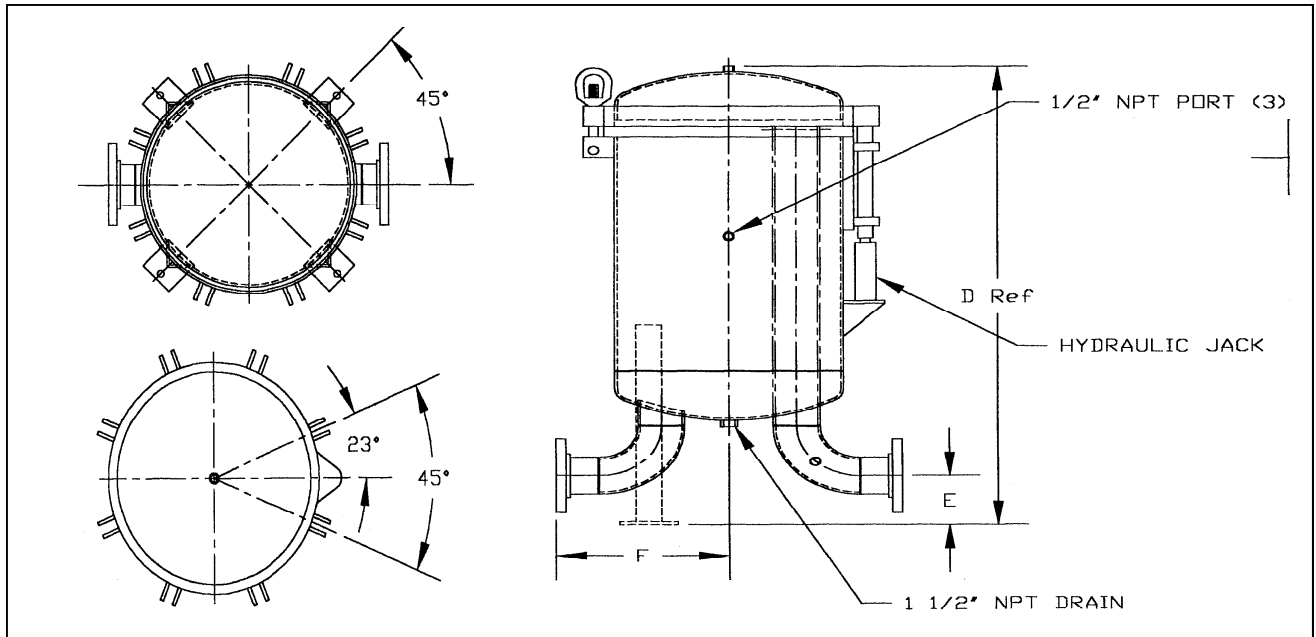

MODEL	# OF BASKETS	STRAINING AREA SQ. FT.	STD PIPE SIZES INCHES	NOMINAL FLOW RATES GPM
18	2	8.8	2,3	400
18	3	13.2	3,4	600
22	4	17.6	3,4	800
24	6	26.4	4,6	1200
30	8	35.2	6,8	1600
36	12	52.8	6,8,10	2400
42	17	74.8	8,10,12	3400

### BUILDING A CSD PART NUMBER

<b>0</b>	<b>18</b>	<b>02</b>	<b>30</b>	<b>4L</b>	<b>020</b>	<b>F</b>	<b>4</b>	<b>B</b>	<b>C</b>
TYPE	VESSEL SIZE	# OF BASKETS / ELEMENTS	ELEMENT LENGTH	# OF LUGS	CONNECTION SIZE	CONNECTION STYLE	IN / OUT LOCATION	SEALS	CONSTRUCTION



**CSD** Custom Service & Design, Inc.

AUBURN HILLS, MI  
 PHONE: 248.340.9005  
 FAX: 248.340.9002  
 WWW.CUSTOMSERVICEANDESIGN.COM

DISTRIBUTED BY: